



AUTOMATION AND DIGITALIZATION

# NAF CHECK TILTING DISC CHECK VALVES

TECHNICAL BULLETIN

**ANDRITZ**

ENGINEERED SUCCESS

# Primary characteristics

The NAF Check valve is available in ANSI and API standards in carbon steel and stainless steel. It is also available in BS, DIN and SS standards – see catalogue sheet Fk 30.70GB.

The characteristics for the valve type are:

- Short face-to-face length – invaluable where the space is limited.
- Low weight results in low handling costs and makes it easier to install.
- Low pressure drop and low opening pressure.
- Fully open with water velocity of only 2.0 ft/s (0.6 m/s) – without closing spring.
- Excellent tightness, better than demanded in API 598.
- Rapid response – oblique seat reduces closing travel.
- Can be furnished with auxiliary spring to reduce water hammering in liquid media.

**CE-marked** according to Pressure Equipment Directive (PED 97/23/EG) module H, category III.

## DESIGN

The circular wafer body is designed to be clamped between two pipe flanges.

The valve disc is suspended on two heavy stub shafts with the selected suspension points giving the fastest closing possible.

The seat is oblique in order to give a short closing travel and a short closing time. NAF Check can also be supplied with an auxiliary spring. Due to the lightweight disc, the auxiliary spring can shorten the closing time further and reduce water hammering to one fourth in comparison to use springless valves at quickly returning liquid flow.

In order to facilitate installation, valves > size 2" are equipped with a lifting eye. A cast arrow on the lifting eye indicates the flow direction.

## FACE-TO-FACE LENGTH

According to ANSI-API 594.

## CONNECTION

NAF Check is intended for clamping between flanges in accordance with ANSI class 150 and 300.

## TEST PRESSURES (TABLE 1)

Pressure Class ANSI	Test pressure, water * 68°F / 20°C	
	Open valve	Closed valve
150	450 psi / 31 bar	319 psi / 22 bar
300	1131 psi / 78 bar	827 psi / 57 bar

\* Leakage never exceeds 0.06 cu in/minute (1 cm<sup>3</sup>/minute) – regardless of connection size – for specified test pressure. Test medium is water.

# Applications

NAF Check can be used in any liquid, gas or vapor which is compatible with the valve itself.

We recommend valves with auxiliary spring for use in liquid flow.

Limitations: See instructions on page 6.

## SELECTION TABLE (TABLE 2)

NAF No.	Size	ANSI class	Material	With spring
526440	18-24"	150	Steel	
526450	18-24"	150	Steel	X
526460*	2-16"	150	Steel	
526461*	3-16"	150	Steel	X
526660*	2-16"	300	Steel	
526661*	3-16"	300	Steel	X
528440	18-24"	150	Stainless steel	
528450	18-24"	150	Stainless steel	X
528460*	2-16"	150	Stainless steel	
528461*	3-16"	150	Stainless steel	X
528660*	2-16"	300	Stainless steel	
528661*	3-16"	300	Stainless steel	X

To be installed between flanges ANSI B16.5 flat face. Ring Joint as extra.  
\* Designed according to API 594.



**WORKING PRESSURES AND TEMPERATURES (TABLE 3)**

NAF No.	Pressure class ANSI	Size	Max. working pressure, psi (e) at temperatures up to °F							
			68	122	212	302	392	482	572	662
5264..	150	2-8"	276	267	235	215	199	175	148	122
5264..	150	10-24"	287	283	257	229	200	175	148	122
5266..	300	2-8"	719	698	612	558	518	484	458	439
5266..	300	10-24"	750	750	747	728	705	672	622	580
5284..	150	2-24"	276	267	235	215	199	175	-	-
5286..	150	2-24"	719	698	612	558	518	484	-	-

NAF No.	Pressure class ANSI	Size	Max. working pressure, bar (e) at temperatures up to °C							
			20	50	100	150	200	250	300	350
5264..	150	2-8"	19	18,4	16,2	14,8	13,7	12,1	10,2	8,4
5264..	150	10-24"	19,8	19,5	17,7	15,8	13,8	12,1	10,2	8,4
5266..	300	2-8"	49,6	48,1	42,2	38,5	35,7	33,4	31,6	30,3
5266..	300	10-24"	51,7	51,7	51,5	50,2	48,6	46,3	42,9	40
5284..	150	2-24"	19	18,4	16,2	14,8	13,7	12,1	-	-
5286..	150	2-24"	49,6	48,1	42,2	38,5	35,7	33,4	-	-

**TEMPERATURE RANGE -22 - 662°F / -30 - 350°C**

NOTE! Flange Pressure and temperature limits.

# Material Specifications

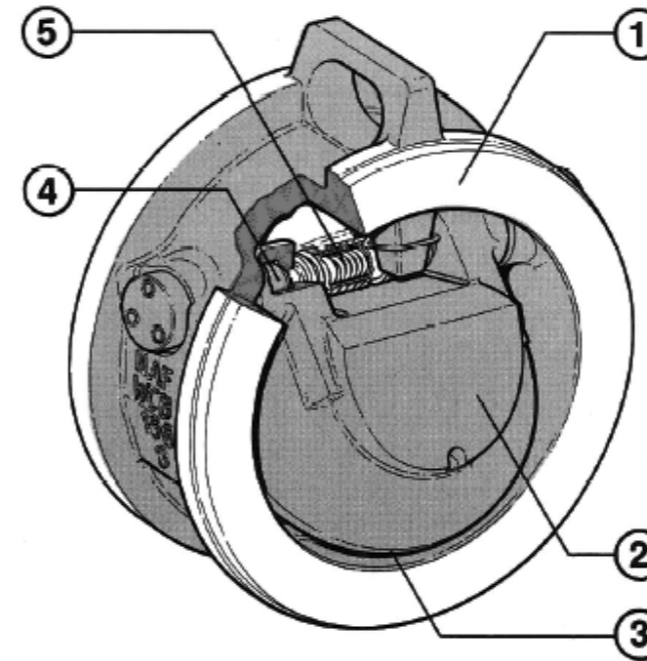

**NAF 5264.., 5266.. (TABLE 4)**

Item	Qty	Part	Material in standard design
1	1	Body	2" ASTM A182 Gr F316 3-8" ASTM A351 Gr CF8M 10-24" ASTM A216 Gr WCC
2	1	Disc	ASTM A487 Gr CA6NM
3		Sealing surfaces	2-8" Directly machined on body and disc 10-24" Body: Deposit-welded, hardened stainless steel. Disc: Direct machined.
4	2	Stub shafts	ASTM A276 type 410
5	1	Spring	ASTM A564 type 635

**NAF 5284.., 5286.. (TABLE 5)**

Item	Qty	Part	Material in standard design
1	1	Body	2" ASTM A182 Gr F316 3-24" ASTM A351 Gr CF8M
2	1	Disc	EN1.4470 / ASTM A240 Gr 329
3		Sealing surfaces	Machined directly in body and disc.
4	2	Stub shafts	ASTM A240 Gr 329
5	1	Spring	ASTM A564 type 635

# Selection of Valve Size and Pressure Drop

In pipes with steam or gases (compressible media) it is important to check that the valve is fully open and the disc is pressed against the stop at all normal operating conditions. This in order to avoid disc flutter giving noise and shorter valve life.

The dynamic opening force on the disc depends on the density of the medium and the flow velocity in the pipe. Use the diagram 1 for vertical pipe and diagram 2 for horizontal pipe. Set the value of  $\rho v^2$  on the horizontal axis and check the curves.

Depending on installation position, the valve without auxiliary spring is fully open if the value  $\rho v^2$  on the horizontal axis is larger than 300 in a vertical pipe, or 650 in a horizontal pipe. Select a smaller size if the valve is not fully open.

Valves with auxiliary spring, which we only recommend for use in liquids - at the risk of water hammering - the corresponding values are 700 and 1300. Read the pressure drop across fully open valve on the vertical axis and at the intersection of the straight line "Fully open valve". The pressure drop is larger if the valve is not fully open (follow resp. line regarding pipe and spring).

The curves in diagram 1 and 2 represent sizes up to size 4". The pressure drop is lower for larger sizes. Reduce the diagram pressure drop values with the following factors:

- Sizes 6-10" factor 0.72
- Sizes 12-18" factor 0.62
- Sizes 20-24" factor 0.38

With flow rate - in water - known in m<sup>3</sup>/h or USG/min the pressure drop across the valve can be read directly in diagram 3.

(TABLE 6) KV AND Z VALUES

Size	Kv	Z
2	51	4,1
3	130	3,2
4	242	2,9
6	555	2,8
8	1045	2,5
10	1632	2,5
12	2505	2,2
14	3410	2,2
16	4560	2,1
18	5770	2,1
20	7125	2,1
24	10260	2,1

PRESSURE DROP - FLOW VELOCITY API 594, ANSI CLASS 150 - 300, VERTICAL PIPE (DIAGRAM 1)

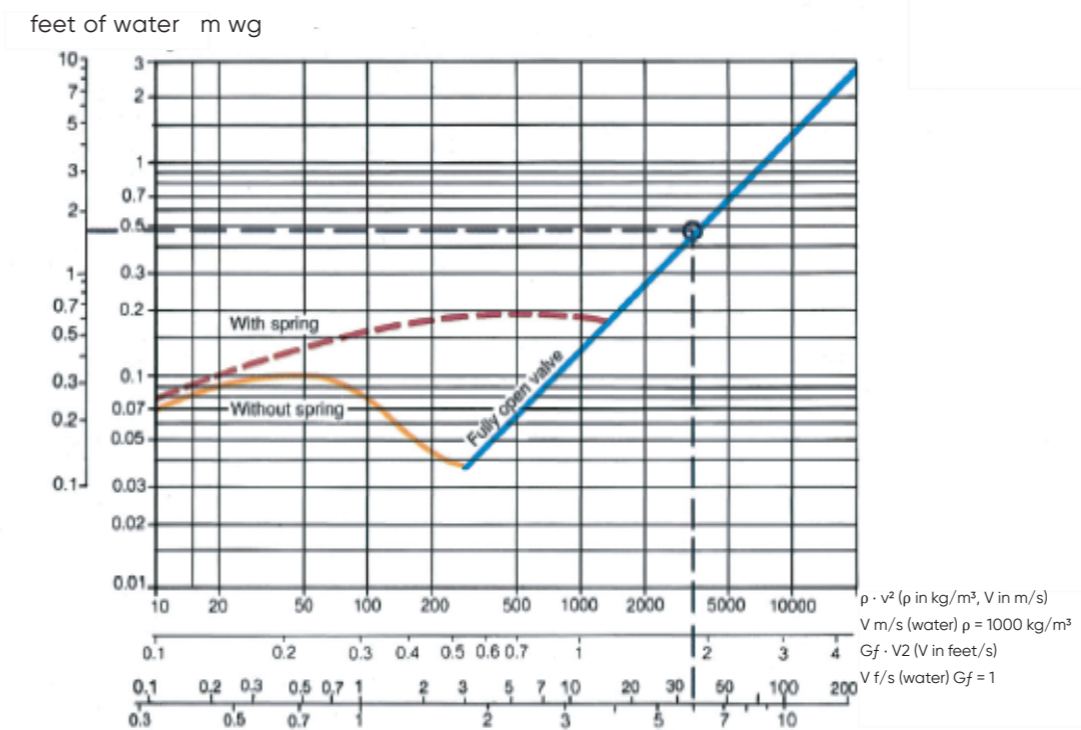

PRESSURE DROP - FLOW VELOCITY API 594, ANSI CLASS 150 - 300, HORIZONTAL PIPE (DIAGRAM 2)

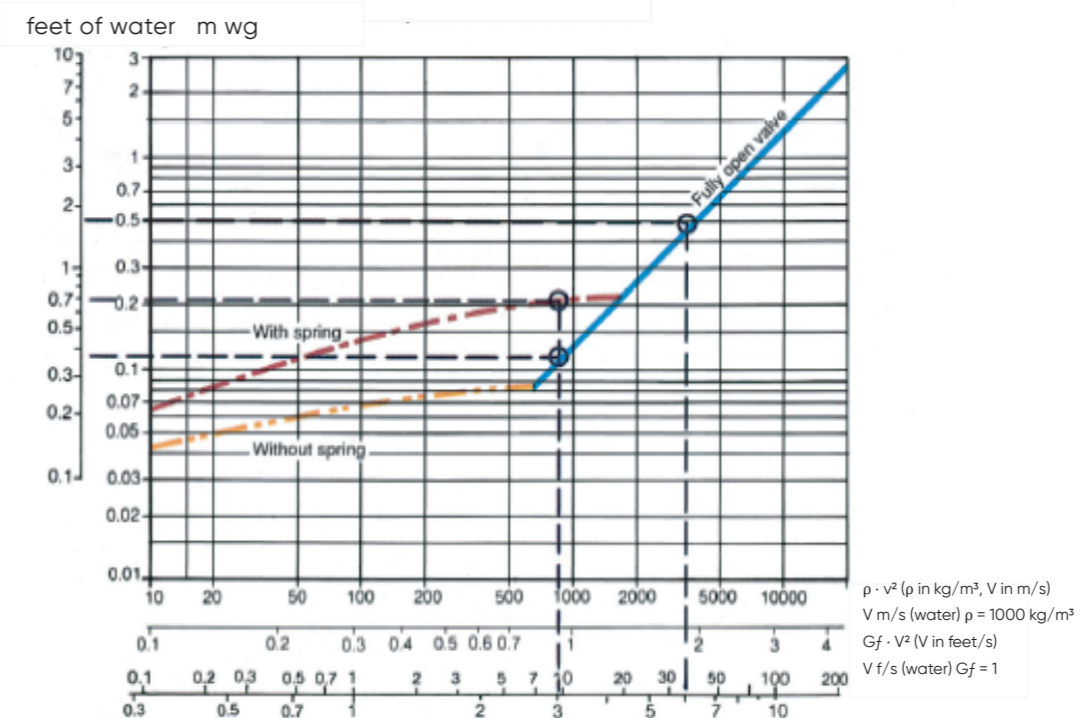

**NOTE**

The curves represent average values for the various valve dimensions. pressure drop may in some cases differ from this chart.

## APPLICATION

Examples:

1. Water Flow velocity 6 ft/s and valve size 4".  
Diagram 1 gives a pressure drop 1.6 ft of water.  
Valve with spring-loaded disc is preferred.  
For the same application but size 12", multiply given pressure drop 1.6 ft of water with factor 0.62 which gives pressure drop 1.0 ft of water.
2. Air Horizontal line with air at normal conditions (0°C and 1 bar abs)  
 $G f = 0.0013$  and flow velocity 85 ft/s.  
 $G f v^2 = 9.4$ 
  - a) Without spring pressure drop 0.38 ft of water. The valve is fully open.
  - b) With spring pressure drop 0.65 ft of water. The valve is not fully open.  
Flutter risk.  
Springless valve is preferred.
3. Water 800 USG/min in a 8" line. Diagram 2 gives a pressure drop of 0.9 ft of water and valve is fully open with spring. If a 10" line, the pressure drop is 0.38 ft of water.  
The valve is fully open without spring but is not fully open with spring.

### PRESSURE DROP - CAPACITY WATER (DIAGRAM 3)

feet of water m wg

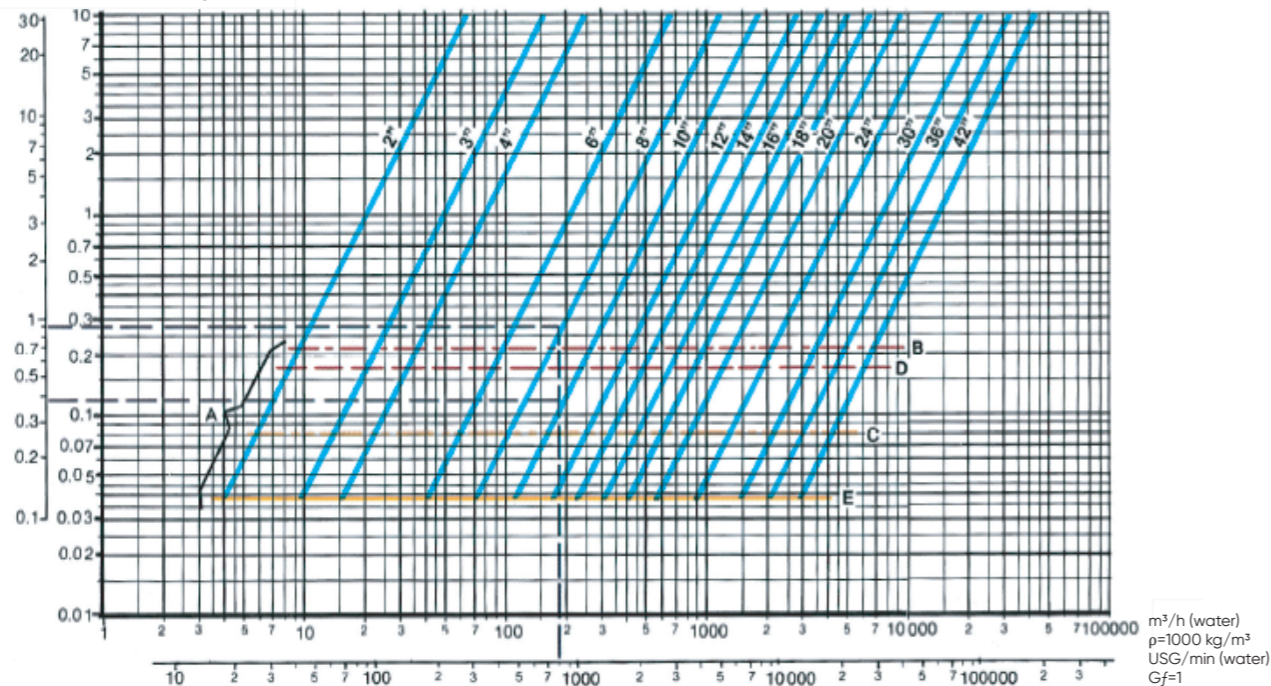

- |  |   |   |
|--|---|---|
| <p><b>A.</b> Before the valve is fully open, the pressure drop across it exceeds the value shown above - see page 7.</p> | <p><b>B.</b> Valve fully open - with spring-assisted disc and as fitted in a horizontal pipe.</p> | <p><b>C.</b> Valve fully open - without spring-assistance and as fitted in a horizontal pipe.</p> |
| <p><b>D.</b> Valve fully open - with spring-assisted disc and as fitted in a vertical pipe.</p>                          | <p><b>E.</b> Valve fully open - without spring-assistance and as fitted in a vertical pipe.</p>   |   |

## LIMITATIONS

Caution should be exercised in certain application areas. These are:

1. Small, pulsating gas flows such as are emitted from a piston compressor. The valve selected in such cases shall be small enough to open fully during normal operations and prevent flutter.
2. Low-pressure gases. The opening dynamic force is affected by density. Make certain that velocity and density are adequate to open the valve - diagram 1.
3. Location on suction side of centrifugal pumps. Place the check-valve on the delivery side to avoid starting and cavitation problems.
4. Pumps in parallel. Make certain that pump characteristics fall the entire flow range.

# Dimension and mass

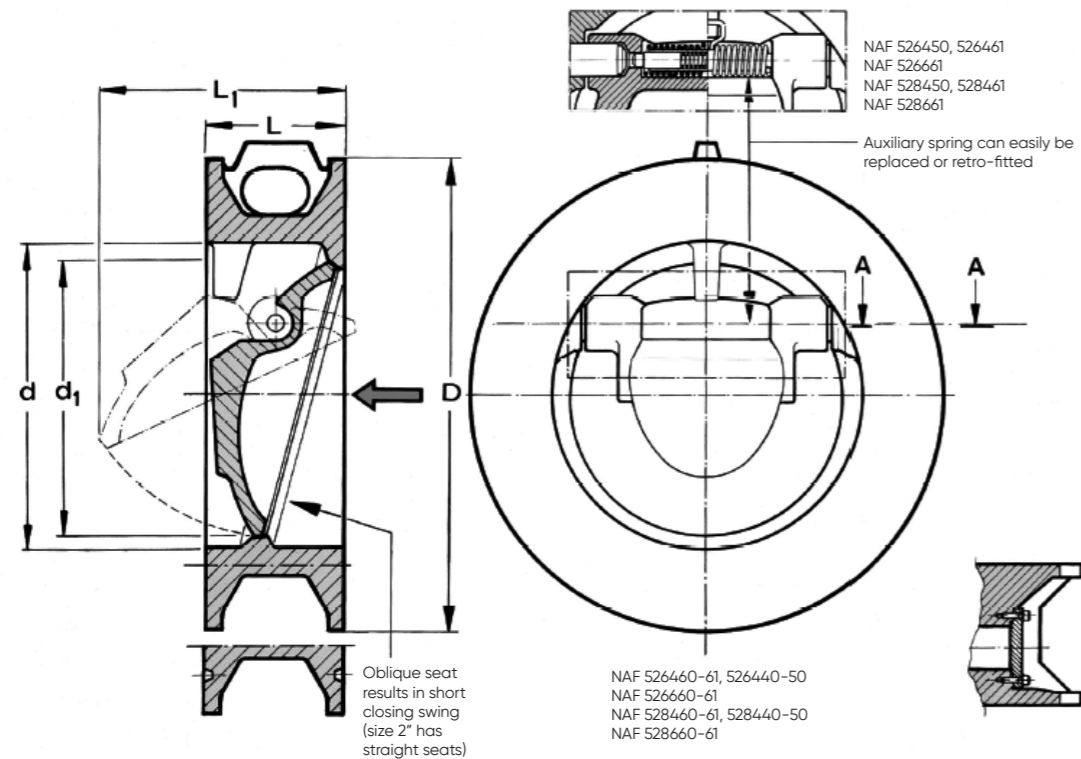

**DIMENSIONS (TABLE 6)**

NAF No.	Size	Inches					Class 150 weight	mm				Weight
		d	D	d1*	L	L1		Lbs	D	d1*	L	
526460-61 528460-61 According to API 594	2	4 1/8	1,46	2 3/8	2 3/16	7	105	37	60	56	3,4	
	3	5 3/8	2,52	2 7/8	3 3/8	9	137	64	73	85	4,3	
	4	6 7/8	3,54	2 7/8	3 3/4	15	175	90	73	95	6,8	
	6	8 3/4	5,51	3 7/8	5 3/8	25	222	140	98	137	11,9	
	8	11	7,28	5	7 1/16	48	279	185	127	179	22	
	10	13 3/8	9,21	5 3/4	8 3/4	78	340	234	146	222	36	
	12	16 1/8	11,26	7 1/8	10 5/8	136	410	286	181	270	62	
	14	17 3/4	12,91	7 1/4	13	141	451	328	184	330	64	
526440-50 528440-50	16	20 1/4	14,80	7 1/2	14 1/4	187	514	376	191	362	85	
	18	21 5/8	16,54	6	13 3/8	212	549	420	152	340	96	
	20	23 7/8	18,35	6 1/4	15	258	606	466	158	380	117	
	24	28 1/4	22,21	7	18 1/8	430	718	564	178	460	195	
						<b>Class 300</b>						
526660-61 528660-61 According to API 594	2	4 3/8	1,46	2 3/8	2 3/16	7,5	111	37	60	56	3,5	
	3	5 7/8	2,52	2 7/8	3 3/8	10	149	64	73	85	4,5	
	4	7 1/8	3,54	2 7/8	3 3/4	17	181	90	73	95	7,7	
	6	9 7/8	5,51	3 7/8	5 3/8	36	251	140	98	137	16,9	
	8	12 1/8	7,28	5	7 1/16	62	308	185	127	179	28	
	10	14 1/4	9,21	5 3/4	8 3/4	86	362	234	146	222	39	
	12	16 5/8	11,26	7 1/8	10 5/8	140	422	286	181	270	64	
	14	19 1/8	12,91	8 3/4	13 3/4	196	486	328	222	350	89	
	16	21 1/4	14,80	9 1/8	15 1/8	212	540	376	223	384	96	

# Connection - Standard Sizes

## STANDARD CONNECTION

In the table below, the valve connections compatible with various flange standards are marked with X.

**(TABLE 7)**

Size	"Raised face" - flanges		"Ring Joint" - flanges**			
	ANSI B 16.5 Slip on, Weld neck Class 150	ANSI B 16.5 Slip on, Weld neck Class 300	ANSI B 16.5 Class 150 Groove Number		ANSI B 16.5 Class 300 Groove Number	
2	x	x	x	22	x	23
3	x	x	x	29	x	31
4	x	x	x	36	x	37
6	x	x	x	43	x	45
8	x	x	x	48	x	49
10	x	x	x	52	x	53
12	x	x	x	56	x	57
14	x*	x*	x*	59	x	61
16	x*	x*	x*	64	x	65
18	x*	x*	x*	68	x	69
20	x*	x*	x*	72	x	73
24	x*	x*	x*	76	x	77

\* Indicates that the customer is responsible for checking the inner diameter of the pipe flange. This inner diameter must not be less than d<sub>i</sub>, see dimension table 6.

\*\* The valve must be specially ordered for Ring Joint.

## ORDERING EXAMPLE

When ordering, please state the NAF number, size and valve type, i.e. as follows:

NAF 526460, 10", NAF Check check valve



## **CONTACT US!**

### **ANDRITZ NAF AB**

NAF Control Valves  
+46-13-316100  
sales.naf@andritz.com

### **ANDRITZ.COM**



All data, information, statements, photographs and graphic illustrations in this leaflet are without any obligation and raise no liabilities to or form part of any sales contracts of ANDRITZ AG or any affiliates for equipment and/or systems referred to herein. © ANDRITZ AG 2024. All rights reserved. No part of this copyrighted work may be reproduced, modified or distributed in any form or by any means, or stored in any database or retrieval system, without the prior written permission of ANDRITZ AG or its affiliates. Any such unauthorized use for any purpose is a violation of the relevant copyright laws. ANDRITZ AG, Stattegger Strasse 18, 8045 Graz, Austria. NAF Check Tilting Disc Check Valves Technical Bulletin EN 1.0/2024.

