



AUTOMATION AND DIGITALIZATION

# NAF CHECK TILTING DISC CHECK VALVES

TECHNICAL BULLETIN

**ANDRITZ**

ENGINEERED SUCCESS

# Primary characteristics

The NAF Check valve is available in BS, DIN and SS standards in carbon steel and stainless steel. It is also available in ANSI and API standards – see catalogue sheet Fk 30.71GB.

Characteristics for the valve type are:

- Suitable for all usable flange standards
- Short face-to-face length - invaluable where space is limited
- Low weight results in low handling costs and ease of installation
- Low pressure drop and low opening pressure
- Fully open with water velocity of only 0.6 m/s - without closing spring
- Excellent tightness, better than demanded in API 598
- Rapid response - oblique seat reduces closing travel
- Can be furnished with auxiliary spring to reduce water hammer in liquid media

**CE-marked** according to Pressure Equipment Directive (PED 97/23/EG) module H, category III.

## DESIGN

The circular wafer body is designed to be clamped between two pipe flanges. A list of the international flange standards to which the valve is adapted is shown on page 8.

The valve disc is suspended on two heavy stub shafts with the selected suspension points giving the fastest closing possible.

The stub shafts are sealed externally by integrally welded plates.

The seat is oblique in order to give a short closing travel and thus a short closing time. NAF Check can also be supplied with an auxiliary spring. Due to the lightweight disc, the auxiliary spring can shorten closing time further and reduce water hammering to one fourth that obtained using springless valves at quickly returning liquid flow.

In order to facilitate installation, valves >DN 50 are equipped with a lifting eye. An arrow cast into the lifting eye indicates the flow direction.

## FACE-TO-FACE LENGTH

According to EN 558-1, Series 16.

## CONNECTION

NAF Check is intended for clamping between flanges and fits most pipe flanges in accordance with DIN, ANSI and BS

## TEST PRESSURES (TABLE 1)

Pressure Class PN	Test pressure bar (e), water *	
	Open valve	Closed valve
40	60	44
25	38	28

\* Leakage never exceeds 1 cm<sup>3</sup>/minute - regardless of connection size - for specified test pressure. Test medium is water.

# Applications

NAF Check can be used in any liquid, gas or vapor which is compatible with the valve itself.

We recommend valves with auxiliary spring for use in liquid flow.

Limitations: See instructions in tables on page 6.

## SELECTION TABLE (TABLE 2)

NAF No.	DN	PN	Material
526520	300-1000	25	Steel
526530*	300-1000	25	Steel
526620	40-250	40	Steel
526630*	65-250	40	Steel
528520	300-1000	25	Stainless steel
528530*	300-1000	25	Stainless steel
528620	40-250	40	Stainless steel
528630*	65-250	40	Stainless steel

\* Valve with auxiliary spring



**WORKING PRESSURES AND TEMPERATURES (TABLE 3)**

NAF No.	PN	DN	Max. working pressure, bar (e) at temperatures up to °C									
			20	50	100	150	200	250	300	350	400	
526620-30	40	40 -250	40	38,6	36,3	32,7	29,9	27,6	25,7	24,5	23,8	
526620-30	40	250	40	40	40	36,3	33,7	31,8	29,7	28,5	27,4	
526520-30	25	300 -1000	25	24,3	23,2	22,0	20,8	19,0	17,2	16,0	14,8	
528620-30	40	40 -250	40	40	40	36,3	33,7	31,8	-	-	-	
528520-30	25	300 -1000	25	25	25	22,7	21,0	19,8	-	-	-	

**TEMPERATURE RANGE -30 - 400°C**

Note! Spring design max 350 °C.

# Material Specifications

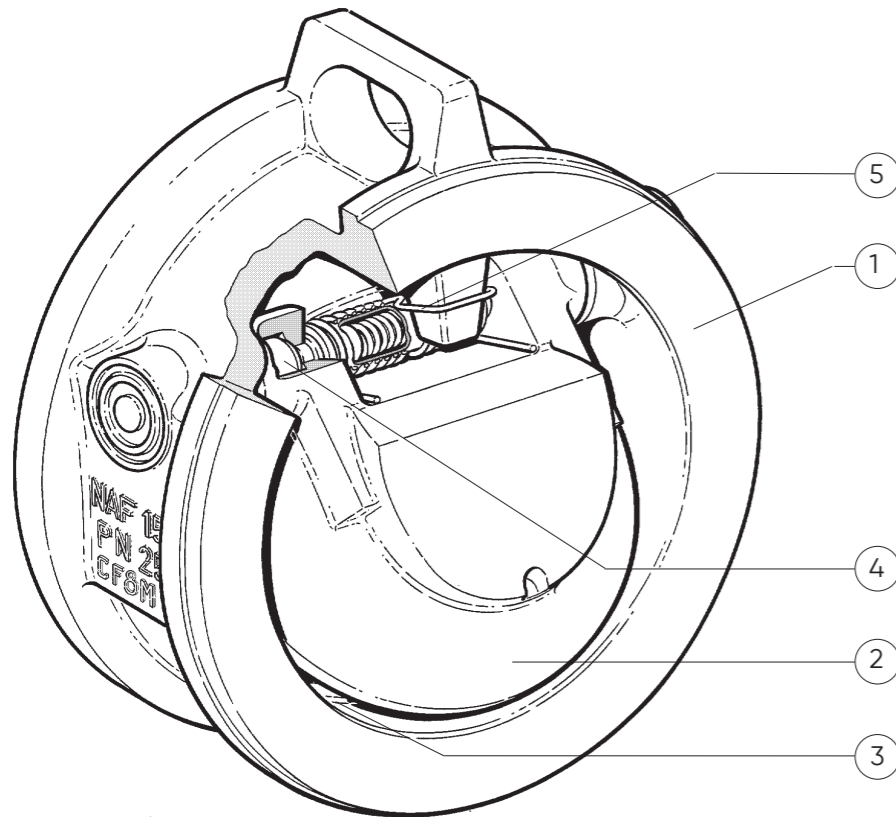

**NAF 5265X0, 5266X0 (TABLE 4)**

Item	Qty	Part	Material in standard design
1	1	Body	DN 40-50 EN 1.4404 / 316L
			DN 65-200 EN 1.4308 / CF8
			DN 250 EN 1.4408 / CF8M
			DN 300-1000 EN 1.0619 / WCC
2	1	Disc	DN 40-50 ASTM A487 Gr CA6NM
			DN 65-1000 EN 1.4317
3		Sealing surfaces	DN 40-125 Directly machined on body and disc DN 150-1000 Body: Deposit-welded, hardened stainless steel. Disc: Direct machined.
4	2	Stub shafts	EN 1.4021 / ASTM A276 type 420
5	2	Spring	EN 1.4568 / ASTM A564 type 635

**NAF 5285X0, 5286X0 (TABLE 5)**

Item	Qty	Part	Material in standard design
1	1	Body	DN 40-50 EN 1.4406 / 316L
			DN 65-1000 EN 1.4408 / CF8M
2	1	Disc	EN 1.4470
3		Sealing surfaces	Machined directly in body and disc.
4	2	Stub shafts	EN 1.4460
5	1	Spring	EN 1.4568 / ASTM A631

# Selection of Valve Size and Pressure Drop

In pipes with steam or gases (compressible media) it is important to check that the valve is fully open and the disc thus pressed against the stop at all normal operating conditions. This in order to avoid disc flutter giving noise and shorter valve life.

The dynamic opening force on the disc depends on density of the medium and flow velocity in the pipe. Use the diagram in fig. 1. Set the value of  $\rho v^2$  on the horizontal axis and check the curves.

Depending on installation position, the valve without auxiliary spring is fully open if the value  $\rho v^2$  on the horizontal axis is larger than 200 (point 2-E) in a vertical pipe, or 400 (point 2-C) in a horizontal pipe. Select a smaller size if the valve is not fully open.

Valves with auxiliary spring, which we only recommend for use in liquids - at the risk of water hammer - the corresponding values are 880 (point 1-D) and 1000 (point 1-B). Read the pressure drop across fully open valve on the vertical axis and at the intersection of the straight line "Fully open valve". The pressure drop is larger if the valve is not fully open (follow resp. line regarding pipe and spring).

The curves in fig. 1 represent sizes up to DN 250. The pressure drop is lower for larger sizes. Reduce the diagram pressure drop values with following factors:

DN 300 - 350	factor 0.89
DN 400 - 700	factor 0.83
DN 750 - 1000	factor 0.78

With flow rate - in water - known in m<sup>3</sup>/h the pressure drop across the valve can be read directly in the diagram - fig. 2.

(TABLE 6) KV AND Z VALUES

Size	Kv	Z
40	41	2,4
50	41	5,8
65	80	4,5
80	121	4,5
100	195	4,2
125	309	4,1
150	450	4
200	842	3,6
250	1316	3,6
300	2011	3,2
350	2727	3,2
400	3699	3
450	4682	3
500	5780	3
600	8325	3
700	11330	3
800	15330	2,8
1000	23850	2,8

## PRESSURE DROP

m wC

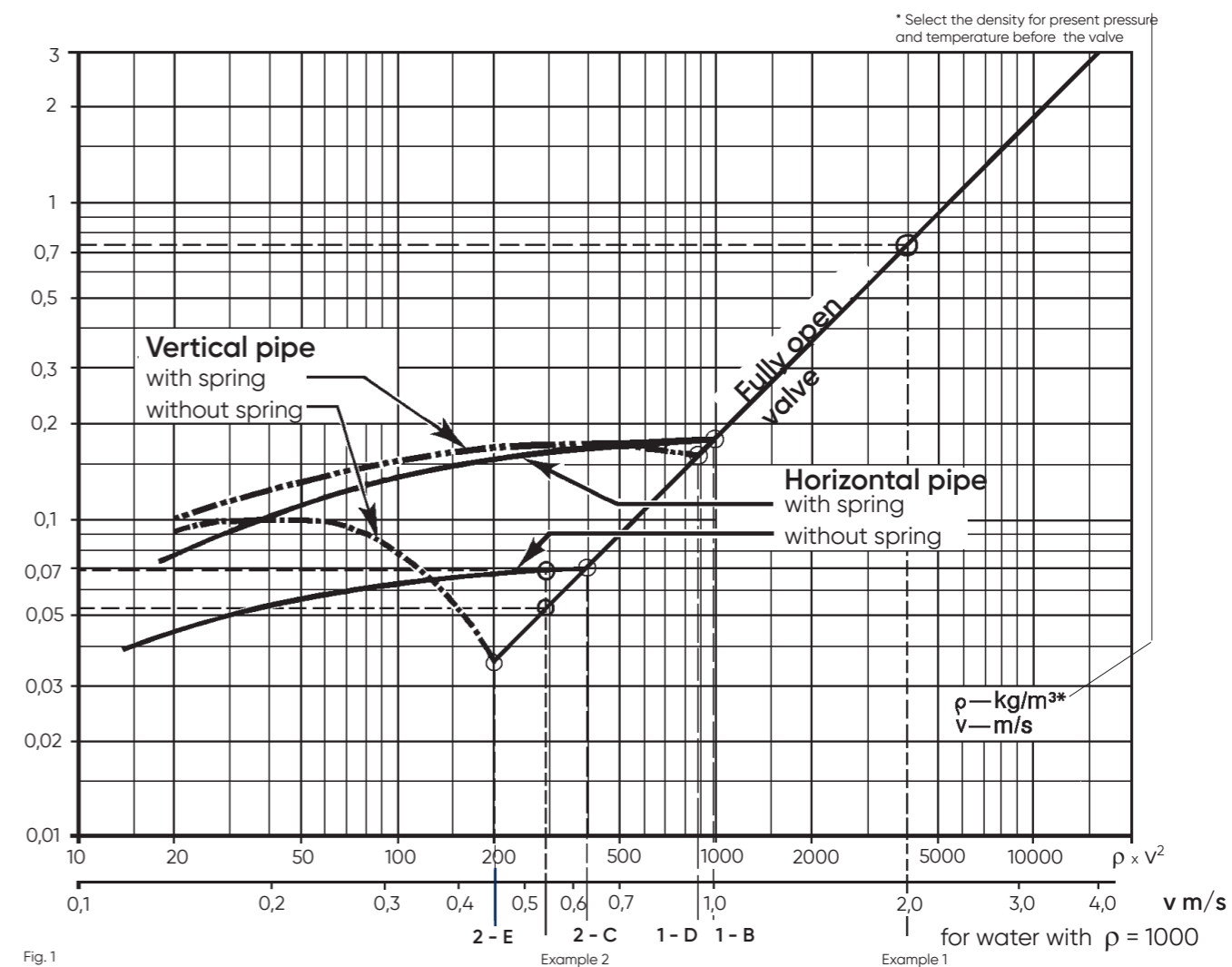
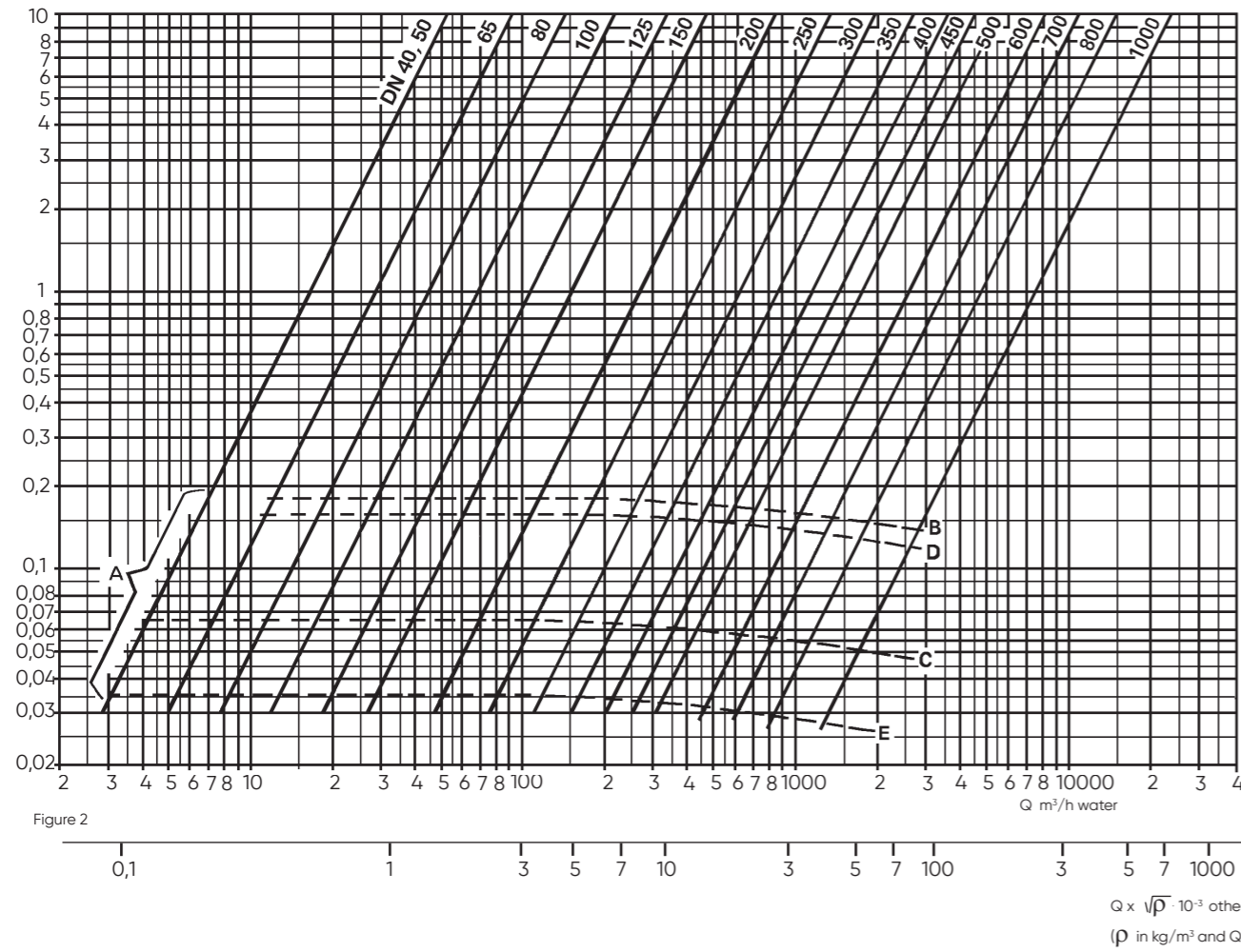

Fig.1

Examples:

- Water Flow velocity 2 m/s  $\rho \times v^2 = 1000 \times 2^2 = 4000$   
Pressure drop 0,73 m wC Select valve with auxiliary spring
- Air Density  $\rho = 1,3 \text{ kg/m}^3$   
Flow velocity 15 m/s  
 $\rho \times v^2 = 1,3 \times 15^2 = 1,3 \times 225 = 292$ 
  - Vertical pipe the valve is fully open. Pressure drop 0,052
  - Horizontal pipe The valve is not fully open - risk of flutter. Select a smaller valve! (Pressure drop 0,07 m wC)

## PRESSURE DROP - CAPACITY



**A.** Before the valve is fully open, the pressure drop across it exceeds the value shown - see fig. 1.

**D.** Valve fully open - with spring - assisted disc and as fitted in a vertical pipe.

**B.** Valve fully open - with spring-assisted disc and as fitted in a horizontal pipe.

**E.** Valve fully open - without spring- assistance and as fitted in a vertical pipe.

**C.** Valve fully open - without spring-assistance and as fitted in a horizontal pipe.

## LIMITATIONS

Caution should be exercised in certain application areas. These are:

1. Small, pulsating gas flows such as are emitted from a piston compressor. The valve selected in such cases shall be small enough to open fully during normal operations, thus preventing flutter.
2. Low-pressure gases. The opening dynamic force is affected by density. Make certain that velocity and density are adequate to open the valve - fig. 1.
3. Location on suction side of centrifugal pumps. Place the check-valve on the delivery side to avoid starting and cavitation problems.
4. Pumps in parallel. Make certain that pump characteristic fall the entire flow range.

# Dimension and mass

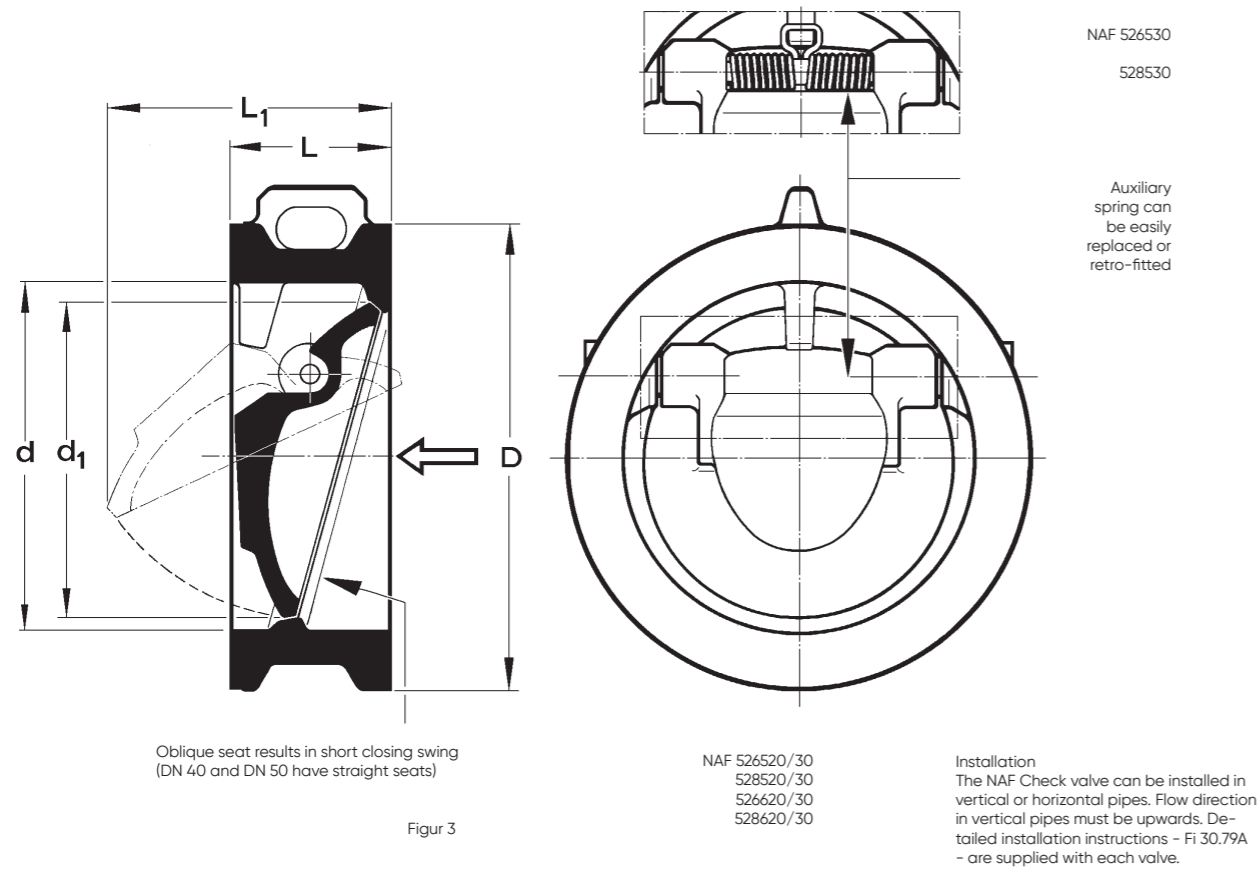

DIMENSIONS IN MM (TABLE 7)

DN	d	d1*	D	L	L 1	Mass kg
<b>NAF 526620/30, 528620/30</b>						
40	50	37	84	33	48	1,2
50	50	37	92	43	48	1,7
65	65	54	108	46	58	1,7
80	80	64	128	64	80	3
100	100	90	158	64	90	5
125	125	110	180	70	106	7
150	150	140	203	76	127	9
200	196	185	263	89	160	16
250	250	234	315	114	204	28
<b>NAF 526520/30, 528520/30</b>						
300	300	286	370	114	239	41
350	350	328	432	127	273	48
400	400	376	480	140	315	65
450	450	420	530	152	340	94
500	500	466	592	152	380	115
600	600	564	692	178	460	192
700	700	656	804	229	530	270
800	800	750	911	241	615	402
1000	1000	930	1124	300	758	782

\* Minimum internal diameter of pipe

## ORDERING EXAMPLE

When ordering, please state the NAF number, size and valve type, i.e. as follows:

follows:

NAF 526460, 10", NAF Check check valve

# Connection - Standard Sizes

## STANDARD CONNECTION

NAF Check is available to fit the majority of standard flanges. In the tables below we have stated the fitting of connections to different standards.

"x" indicates that the connection fits.

"-" indicates that this connection is not available to present standard.

"T" indicates that the internal diameter of the pipe flange must be checked by the purchaser. The diameter must not be less than d1 as shown in the table on page 7.

"ø" indicates use of 29" flanges.

"α" indicates use of 33" flanges."

"·" indicates use of 39" flanges.

See also Fk 30.71GB, describing NAF Check according to API 594, ANSI B 16,5 Class 150-300.

NAF 526620/30 AND 528620/30 (TABLE 8)

DN	DIN				ANSI		BS10 table E, F H	D BS 4504:1969 table N	
	PN10 2632	PN16 2633	PN25 2634	PN40 2635	Slip on 150, 300	Weld neck 150, 300		10/2, 16/2 25/2, 40/2	10/5, 16/5 25/5, 40/5
40	x	x	x	x	x	x	x	x	x
50	x	x	x	x	x	x	x	x	x
65	x	x	x	x	-	x	x	x	x
80	x	x	x	x	-	x	x	x	x
100	x	x	x	x	-	x	x	x	x
125	x	x	x	x	-	x	x	x	x
150	x	x	x	x	-	x	x	x	x
200	x	x	x	x	-	x	x	x	x
250	x	x	x	x	-	x	x	x	x

NAF 526520/30 AND 528520/30 (TABLE 9)

DIN	DIN SS			ANSI Slip on, Weld neck 150 lb/sqin	ANSI 125 to B16.1	BS10 Table E, F	BS 4504:1969 Table						
	PN 10 2632 2032	PN 16 2633 2033	PN 25 2634 2034				Weld neck			Slip on			
							10/2	16/2	25/2	10/5	16/5	25/5	
300	x	x	x	x	-	x	x	x	x	x	x	x	x
350	x	x	x	xT	-	x	x	x	x	-	-	-	-
400	x	x	x	xT	-	x	x	x	x	-	-	-	-
450	x	x	x	xT	-	x	-	-	-	-	-	-	-
500	x	x	x	xT	-	x	x	x	x	-	-	-	-
600	x	x	x	xT	-	x	x	x	x	-	-	-	-
700	x	x	x	-	-	ø	x	x	x	-	-	-	-
800	x	x	x	-	-	α	x	x	x	-	-	-	-
1000	x	x	x	-	-	·	x	x	x	-	-	-	-



## **CONTACT US!**

### **ANDRITZ NAF AB**

NAF Control Valves  
+46-13-316100  
sales.naf@andritz.com

### **ANDRITZ.COM**



All data, information, statements, photographs and graphic illustrations in this leaflet are without any obligation and raise no liabilities to or form part of any sales contracts of ANDRITZ AG or any affiliates for equipment and/or systems referred to herein. © ANDRITZ AG 2024. All rights reserved. No part of this copyrighted work may be reproduced, modified or distributed in any form or by any means, or stored in any database or retrieval system, without the prior written permission of ANDRITZ AG or its affiliates. Any such unauthorized use for any purpose is a violation of the relevant copyright laws. ANDRITZ AG, Stattegger Strasse 18, 8045 Graz, Austria. NAF Check Tilting Disc Check Valves Technical Bulletin EN 1.0/2024.

